



HYDRANTS

QUARTERHORSE 1/4 TURN NON-FREEZE WALL HYDRANT WITH INTEGRAL VACUUM BREAKER AND STAINLESS STEEL BOX BOX TYPE WITH CONCEALED HOSE CONNECTION

FUNCTION: Provides positive non-freeze protection where water is required at the outside of the building and features an integral vacuum breaker. The stainless steel recessed box conceals the nozzle and operating mechanism. The locking cover prevents unauthorized use.

1/4 Turn of the Key Allows Full Flow to Be Obtained

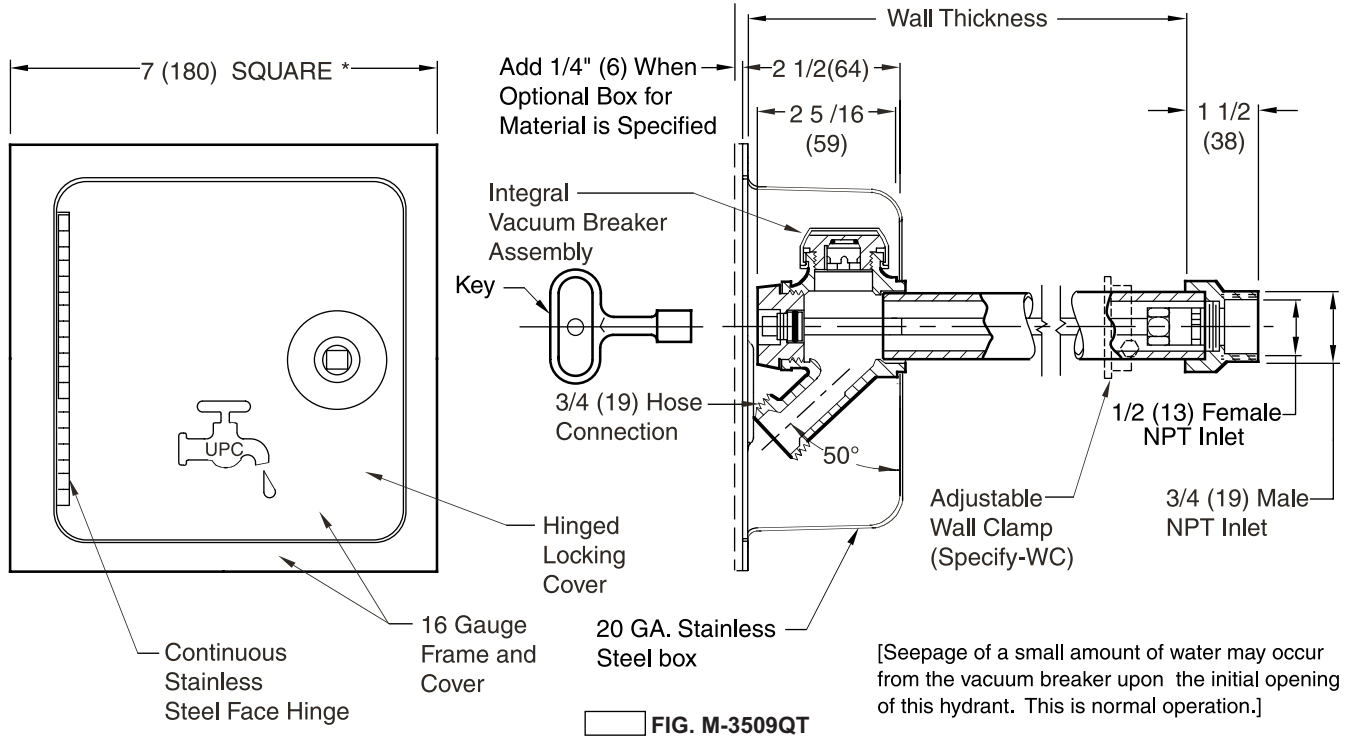

FIG. M-3509QT

REGULARLY FURNISHED:

Bronze Nickel Plated Quarter Turn Self Draining Non-Freeze Hydrant with Hose Connection, Integral Vacuum Breaker, "T" Handle Key, and Stainless Steel Box with Full 180° Cover Opening.

VARIATIONS:

- Adjustable Wall Clamp -WC
- Cylinder Lock -CL
- 1" (25) Hose Connection -HC1
- 1" (25) Male NPT Inlet Connection -IC1
- "Water" On Cover -W

OPTIONAL MATERIALS:

- Nickel Bronze Box Face -NB
- Polished Bronze Box Face -PB
- Rough Bronze Box Face -RB
- Chrome Plated Face -CP

** Add 3/4" (19) to Overall Length When Specified

- NOTES:**
- *Recommended wall opening 6" (150) x 6" (150). Hydrant shall be in the vertical position only, the connection must be on the bottom.
 - When ordering, specify wall thickness in 2" (51) increments as follows: 06(150), 08(205), 10(255), 12(305), 14(355), 16(405), 18(455), 20(510), 22(560) or 24(610). When wall clamp -WC is desired, increase wall thickness dimension by 2" (51).
 - All hydrants are manufactured with "NO-LEAD" brazing rings, and USDA approved lubricants.
 - When an Optional Box Face Material is Specified a Concealed Hinge will be Provided, also Add 1/4" (6) to Flange Thickness.
 - The AB1953, California Lead Law, and NSF/ANSI Standard 61-2008 - Drinking Water System Components are not applicable to hydrants as they do not convey/dispense water for human consumption through drinking or cooking.
 - Dimensions shown in parentheses are in millimeters.
 - FOR IRRIGATION PURPOSES ONLY

Please visit www.murdockmfg.com for most current specifications.

PATENTED

MURDOCK MFG. • 15125 Proctor Avenue • City of Industry, CA 91746 USA
Phone 800-453-7465 or 626-333-2543 • Fax 626-855-4860 • www.murdockmfg.com

Member of
MORRIS GROUP
INTERNATIONAL

M-3509QT

REV. 02/26/14



HYDRANTS

Hydrant Part List

**QUARTERHORSE
1/4 TURN NON-FREEZE
WALL HYDRANT**

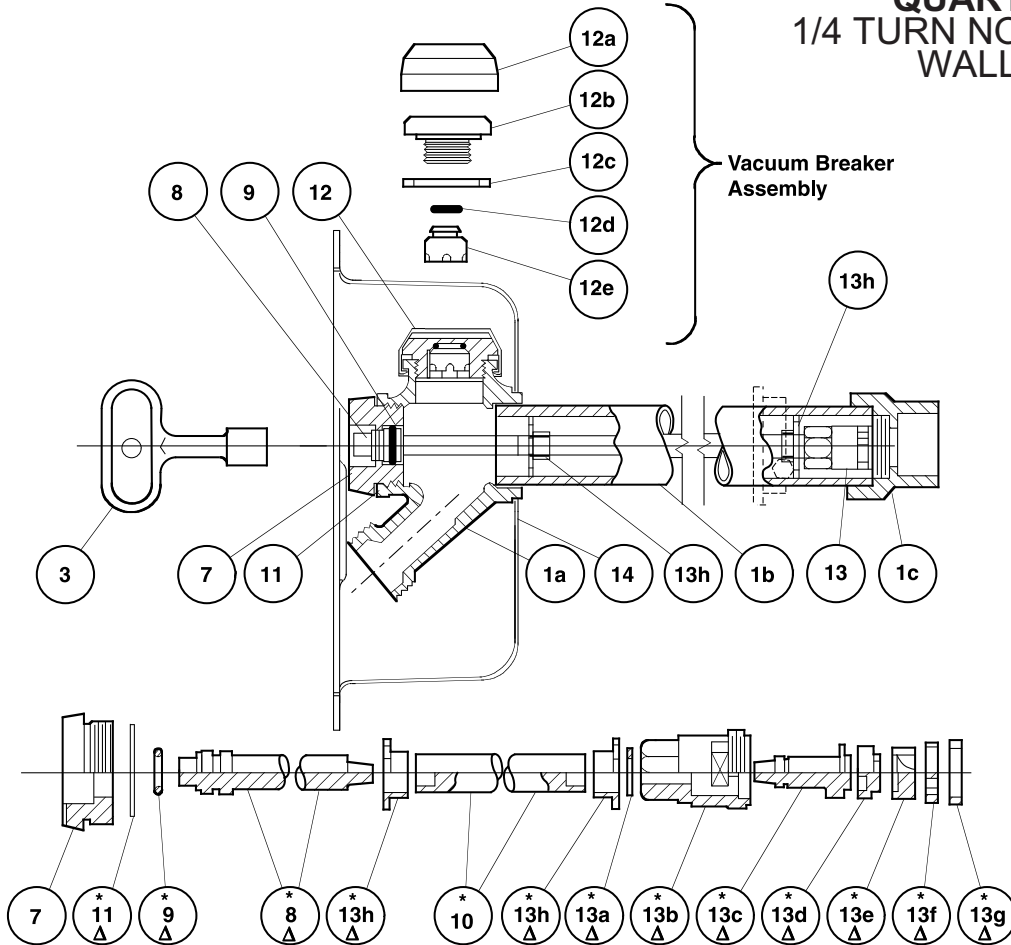

Δ These Replacement Parts Available in HPRK-7

* All Parts Accessible from Face of Hydrant by Removing Face Nut.

HYDRANT PARTS LIST					
NO.	DESCRIPTION	NO.	DESCRIPTION	NO.	DESCRIPTION
1	Head/Casing Assembly	10	Operator Rod	13a	Retaining Ring
1a	Head	11	Face Nut Washer	13b	Valve Body
1b	Casing	12	Vacuum Breaker Assembly	13c	Valve Actuator
1c	Valve Housing	12a	VB Cap	13d	Nylon Thrust Washer
3	Key	12b	VB Body	13e	Rotating Ceramic Disc
7	Face Nut	12c	VB Washer	13f	Fixed Ceramic Disc
8	Actuator Shaft	12d	VB "O" Ring	13g	Silicon Rubber Seal
9	Actuator "O" Ring	12e	VB Piston	13h	Retainer Guide (2)
		13	Valve Body Assembly	14	Box Assembly S.S.

ONE YEAR LIMITED WARRANTY - Parts are warranted for one (1) year from date of shipment.

SELECTION SUMMARY & APPROVAL FOR MANUFACTURING	
<small>All dimensions are subject to manufactures tolerance of plus or minus 1/2" nominal and subject to change without notice. Murdock Mfg. assumes no responsibility for use of void or superseded data. Dimensions may change with the addition of optional accessories. Murdock Mfg.™, Member of Morris Group International™. Please visit www.Murdockmfg.com for most current specifications.</small>	Model Numbers & Options _____ Quantity _____
	Company _____ Date _____
	Contact _____ Title _____
	Approval for Manufacturing/Signature _____