



CONTEMPORARY DRINKING FOUNTAINS

GR Series

MODEL GRT75-PF
OUTDOOR PET FOUNTAIN

STANDARD FEATURES

- Resistant to sunlight, heat, moisture and wear
- 18 gage, 304 stainless steel bowl
- 12 gage, heavy duty steel receptor, corrosion and scratch resistant finish
- Polished stainless steel, anti-rotation non-squirt bubbler
- 100 mesh inlet strainer



SUGGESTED SPECIFICATIONS

Model GRT75-PF is an on-the-floor, outdoor pet fountain intended for wall mounting. The unit shall be made from an 18 gage, 304 stainless steel bowl mounted into a green powder coated 12 gage, heavy duty stainless steel receptor. Unit shall be activated by a side mounted, foot operated, self-closing button, and requiring less than 5 pounds of force to operate. Internally mounted valve includes an adjustable stream regulator controlling the water flow. Bubbler shall be polished stainless steel with a non-squirt feature and operate on water pressure range of 20-105 psig. Unit shall adhere to NSF/ANSI 61, Section 9, Public Law 111-380 (NO-LEAD), and CHSC 116875.

MODEL:

(Must Specify)

- GRT74-PF Satin stainless finish
 - GRT75-PF Green powder-coated (Shown)
 - GRT76-PF Red powder-coated
 - GRT77-PF Blue powder-coated
- Custom color finishes available upon request

OPTIONS

(additional costs may be incurred)

- FRU1 Underground freeze-resistant valve for one bowl ¹
- NP1 Non-pollutable, freeze resistant valve ¹
- RFS Round free standing bowl

Options Notes:

¹ See separate option sheet.



Member of
U.S. Green
Building
Council



Recyclable
Product



Water
Conserving
Product

Please visit www.murdockmfg.com
for most current specifications.

Complies
with the
following
standards:



MURDOCK MFG. • 15125 Proctor Avenue • City of Industry, CA 91746 USA
Phone 800-453-7465 or 626-333-2543 • Fax 626-855-4860 • www.murdockmfg.com

Member of
MORRIS GROUP
INTERNATIONAL



CONTEMPORARY DRINKING FOUNTAINS

All dimensions are subject to manufactures tolerance of plus or minus 1/8" nominal and subject to change without notice. Murdock Mfg. assumes no responsibility for use of void or superseded data. Dimensions may change with the addition of optional accessories. Murdock Mfg.™, Member of Morris Group International™. Please visit www.Murdockmfg.com for most current specifications.

GR Series MODEL GRT75-PF OUTDOOR PET FOUNTAIN

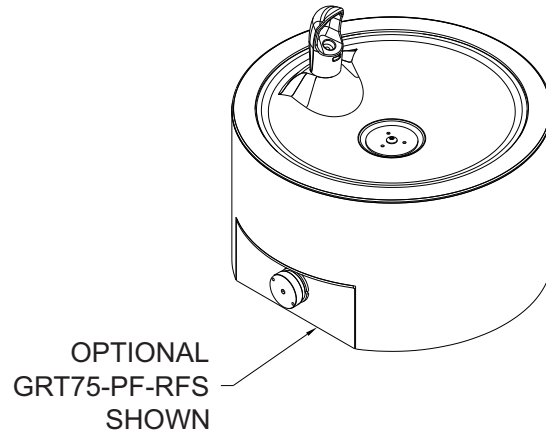
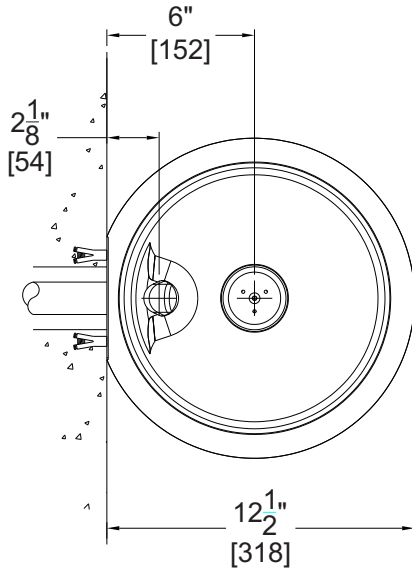

* Valve specifications:
Minimum/Maximum Pressure
30 to 100 psi.

GENERAL NOTES:

1. ALL DIMENSIONS ARE IN INCHES [MM].
2. STOP VALVE NOT PROVIDED.

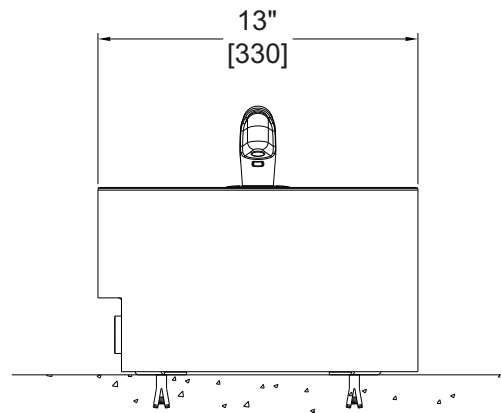
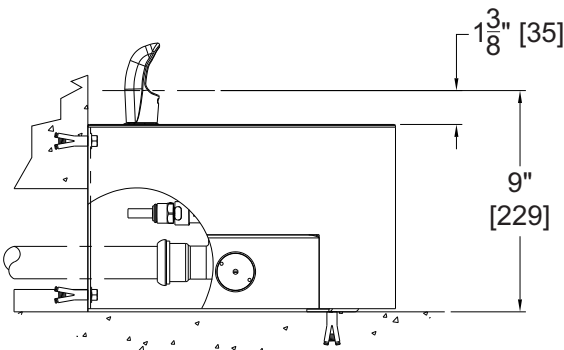

Murdock Mfg.™ warrants that its products are free from defects in material or workmanship under normal use and service for a period of one year from date of shipment. Murdock's liability under this warranty shall be discharged solely by replacement or repair of defective material, provided Murdock™ is notified in writing within one year from date of shipment, F.O.B. Industry, California.

SELECTION SUMMARY
& APPROVAL FOR
MANUFACTURING

Model Number & Options _____	Quantity _____
Company _____	
Contact _____	Title _____
Signature (Approval for Manufacturing) _____	Date _____

All dimensions are subject to manufactures tolerance of plus or minus 1/8" nominal and subject to change without notice. Murdock assumes no responsibility for use of void or superseded data. Dimensions may change with the addition of optional accessories. Murdock Mfg.™, Member of Morris Group International™. Please visit www.murdockmfg.com for most current specifications.