



P.O. Box 22326  
Lincoln, NE 68542

PF: 402/421-9464 | WEBSITE: [www.sitescapesonline.com](http://www.sitescapesonline.com)  
FX: 402/421-9479 | E-MAIL: [info@sitescapesonline.com](mailto:info@sitescapesonline.com)

TITLE *JORDAN CREEK  
BACKED BENCH*

PRODUCT NO.  
*JC1-1000*

INCH TOLERANCES U.O.S.  
FRACTION--  $\pm 1/16"$   
ANG-----  $\pm 1^\circ$

THE INFORMATION CONTAINED IN THIS DRAWING IS THE SOLE PROPERTY OF SITESCAPES, INC. ANY REPRODUCTION IN PART OR AS A WHOLE WITHOUT THE WRITTEN PERMISSION OF SITESCAPES, INC. IS PROHIBITED.

\*Available in powder coat and DuraCoat finishes

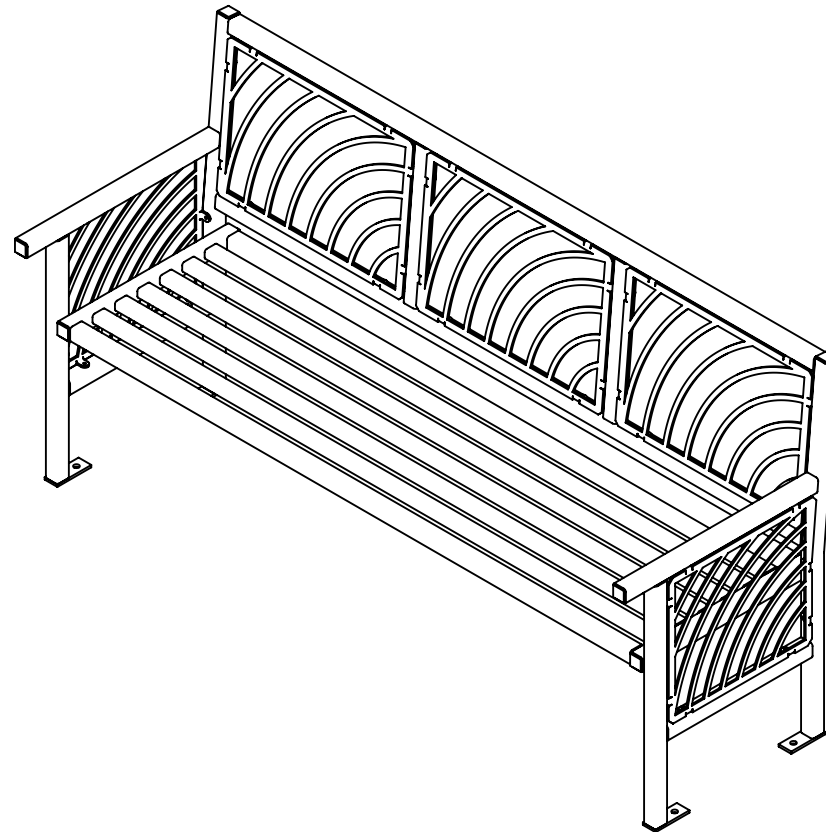



P.O. Box 22326  
Lincoln, NE 68542

PF: 402/421-9464  
FX: 402/421-9479

WEBSITE: [www.sitescapesonline.com](http://www.sitescapesonline.com)  
E-MAIL: [info@sitescapesonline.com](mailto:info@sitescapesonline.com)

TITLE *JORDAN CREEK  
BACKED BENCH*

PRODUCT NO.  
*JC1-1000*

FRACTION--  $\pm 1/16"$   
ANG-----  $\pm 1^\circ$

THE INFORMATION CONTAINED IN THIS DRAWING IS THE SOLE PROPERTY OF SITESCAPES, INC. ANY REPRODUCTION IN PART OR AS A WHOLE WITHOUT THE WRITTEN PERMISSION OF SITESCAPES, INC. IS PROHIBITED.

\*Available in powder coat and DuraCoat finishes

MATERIALS LIST

- (1) Frame - 1 1/2" Sq. x 1/8" Wall Steel Tubing
- (2) Panels - 7 Ga. Steel Sheet Metal
- (3) Foot Plates - 1/4" x 1 1/2" Stainless Steel Flat Bar with  $\phi 9/16"$  Mounting Holes
- (4) Mounted with Four  $\phi 1/2"$  x 4-5" Stainless Steel Anchor Bolts (Customer Supplied)

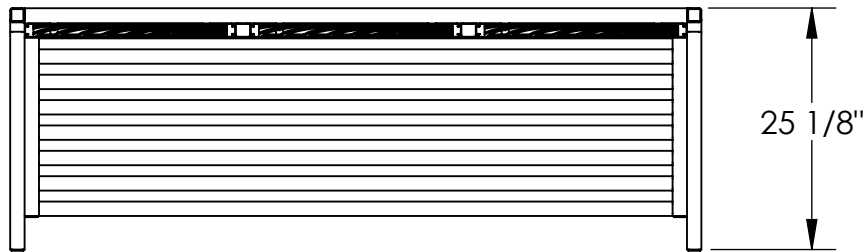

TOP VIEW

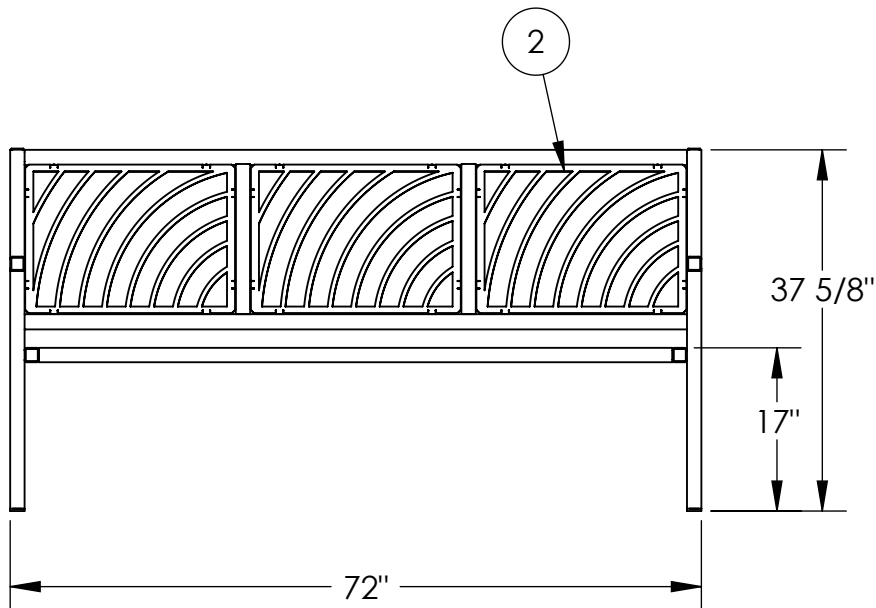

FRONT VIEW

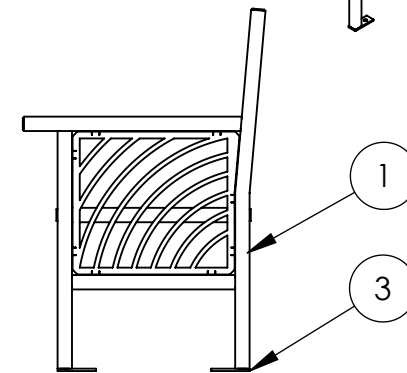
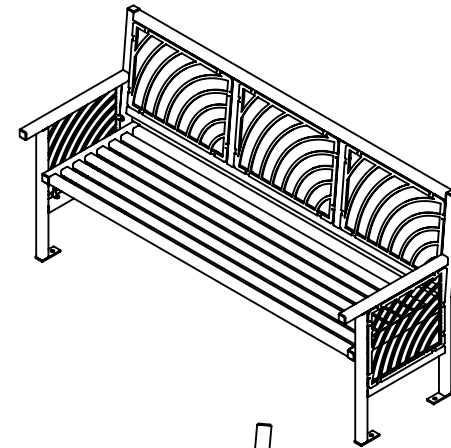

14" CENTER OF HOLES

RIGHT SIDE VIEW