



P.O. Box 22326  
Lincoln, NE 68542

PF: 402/421-9464 | WEBSITE: [www.sitescapesonline.com](http://www.sitescapesonline.com)  
FX: 402/421-9479 | E-MAIL: [info@sitescapesonline.com](mailto:info@sitescapesonline.com)

INCH TOLERANCES U.O.S.

THE INFORMATION CONTAINED IN THIS DRAWING IS THE SOLE PROPERTY OF SITESCAPES, INC. ANY REPRODUCTION IN PART OR AS A WHOLE WITHOUT THE WRITTEN PERMISSION OF SITESCAPES, INC. IS PROHIBITED.

TITLE *AVONDALE  
TABLE & BENCHES*

PRODUCT NO.  
*AV6-5461-ADA-RP*

FRACTION--  $\pm 1/16"$   
ANG-----  $\pm 1^\circ$

\*Available in powder coat and DuraCoat finishes

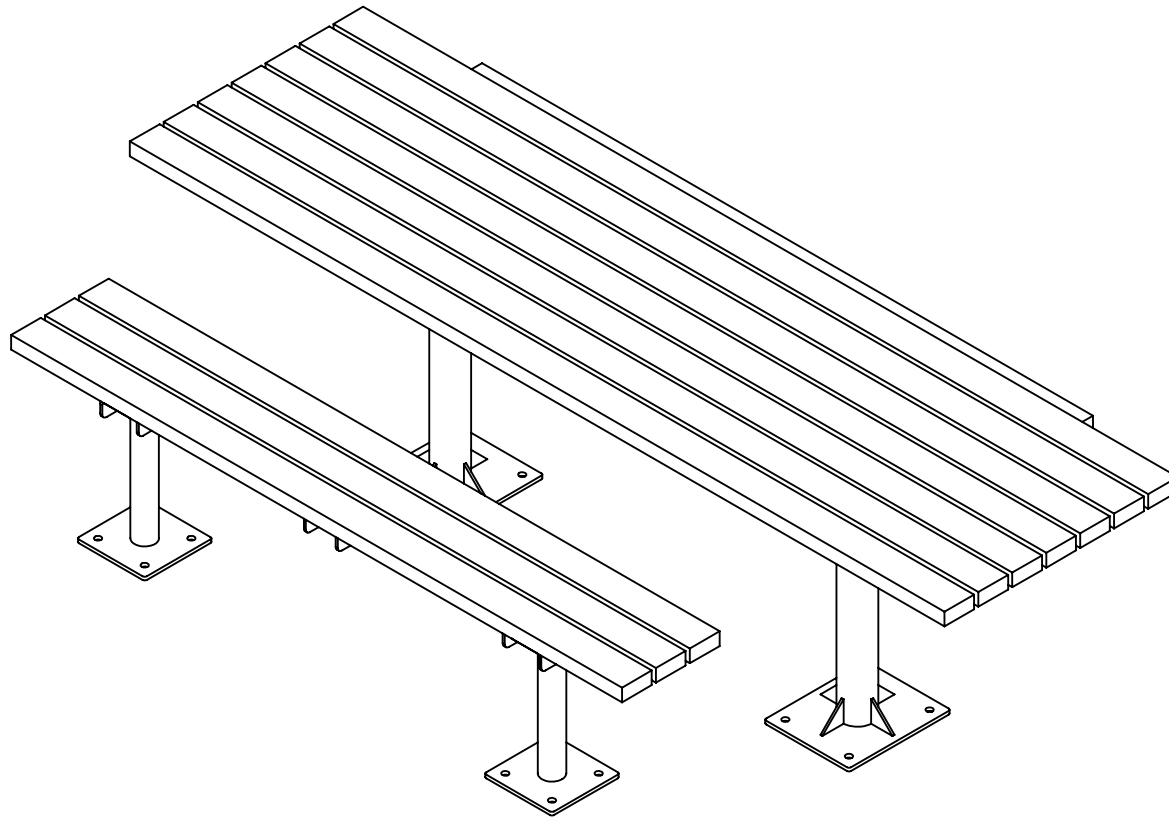



P.O. Box 22326  
Lincoln, NE 68542

PF: 402/421-9464 | WEBSITE: [www.sitescapesonline.com](http://www.sitescapesonline.com)  
FX: 402/421-9479 | E-MAIL: [info@sitescapesonline.com](mailto:info@sitescapesonline.com)

INCH TOLERANCES U.O.S.  
FRACTION-- $\pm 1/16$ "  
ANG----- $\pm 1^\circ$

THE INFORMATION CONTAINED IN THIS DRAWING IS THE SOLE PROPERTY OF SITESCAPES, INC. ANY REPRODUCTION IN PART OR AS A WHOLE WITHOUT THE WRITTEN PERMISSION OF SITESCAPES, INC. IS PROHIBITED.

TITLE *AVONDALE  
TABLE & BENCHES*

PRODUCT NO.  
*AV6-5461-ADA-RP*

\*Available in powder coat and DuraCoat finishes

MATERIALS LIST:

Table:

- (1) Table Top Slats - 2" x 4" Nominal Recycled Plastic
- (2) Base Tubing -  $\phi 3 1/2$ " Steel Tubing
- (3) Support Plates - 3/8" Steel Plate
- (4) Surface Plates - 3/8" Stainless Steel Plate

Bench:

- (5) Bench Slats - 2" x 4" Nominal Recycled Plastic
- (6) Base Tubing -  $\phi 2 3/8$ " Steel Tubing
- (7) Support Plates - 1/4" Steel Plate
- (8) Surface Plates - 3/8" Stainless Steel Plate

