



P.O. Box 22326
Lincoln, NE 68542

PF: 402/421-9464 | WEBSITE: www.sitescapesonline.com
FX: 402/421-9479 | E-MAIL: info@sitescapesonline.com

TITLE
*AVONDALE
RECEPTACLE*

PRODUCT NO.
AV2-3002

INCH TOLERANCES U.O.S.

FRACTION-- $\pm 1/16"$
ANG----- $\pm 1^\circ$

THE INFORMATION CONTAINED IN THIS DRAWING IS THE SOLE PROPERTY OF SITESCAPES, INC. ANY REPRODUCTION IN PART OR AS A WHOLE WITHOUT THE WRITTEN PERMISSION OF SITESCAPES, INC. IS PROHIBITED.

*Available in powder coat and DuraCoat finishes

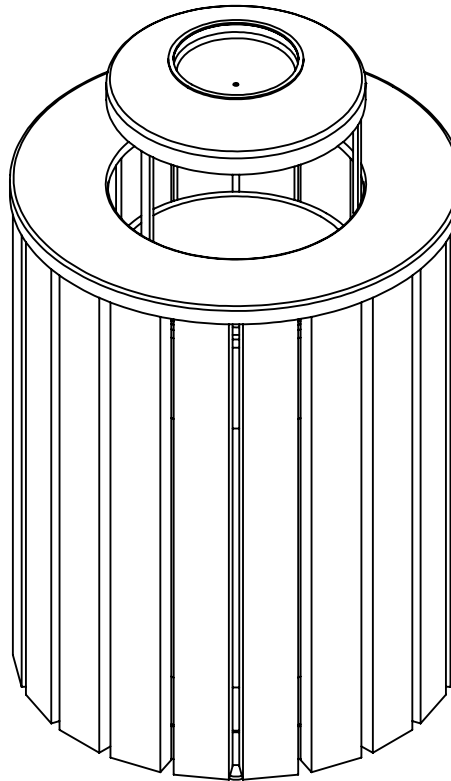



P.O. Box 22326
Lincoln, NE 68542

PF: 402/421-9464 | WEBSITE: www.sitescapesonline.com
FX: 402/421-9479 | E-MAIL: info@sitescapesonline.com

TITLE
*AVONDALE
RECEPTACLE*

PRODUCT NO.
AV2-3002

INCH TOLERANCES U.O.S.
FRACTION-- $\pm 1/16$ "
ANG----- $\pm 1^\circ$

THE INFORMATION CONTAINED IN THIS DRAWING IS THE SOLE PROPERTY OF SITESCAPES, INC. ANY REPRODUCTION IN PART OR AS A WHOLE WITHOUT THE WRITTEN PERMISSION OF SITESCAPES, INC. IS PROHIBITED.

*Available in powder coat and DuraCoat finishes

Materials List

- (1) Wood Slats - 2" x 4" Ipe Wood
- (2) Support Ring - 7 Ga. Laser Cut Steel Sheet
- (3) Support Bars - 3/8" x 3/4" Steel Flat Bar
- (4) Surface Mount Plates - 1/4" x 1 1/2" Stainless Steel Plate with 9/16" Mounting Hole
- (5) Lid - $\phi 24$ " x .075" Wall Steel Lid w/ Dome Ash Top Attached to Basket with Stainless Steel Airline Cable
- (6) Mounted with Three $\phi 1/2$ " x 4-5" Stainless Steel Anchor Bolts (Customer Supplied)
- (7) 32 Gallon Rigid Plastic Liner with Handles Included

